

Brochure

DOMMO PARK



DOMMO PARK
BUSINESS CENTER



Ubicado en el centro neurálgico de la ciudad de Neuquén. Sobre el área administrativa y comercial; Localizado en la calle Santiago del Estero entre Juan B. Justo y San Martín se encuentra Dommo Park Bussines Center.

Un edificio diseñado **pensando en el presente y futuro**, el cual cumple con los requisitos y exigencias que nos demanda esta nueva era, la tecnológica, digital, sustentable, y las nuevas prácticas de negocios y laborales.

El lugar donde
inician **tus sueños**





LOCAL COMERCIAL

PB | Nivel 1



LOCAL COMERCIAL

PB

Superficie: 58 m²

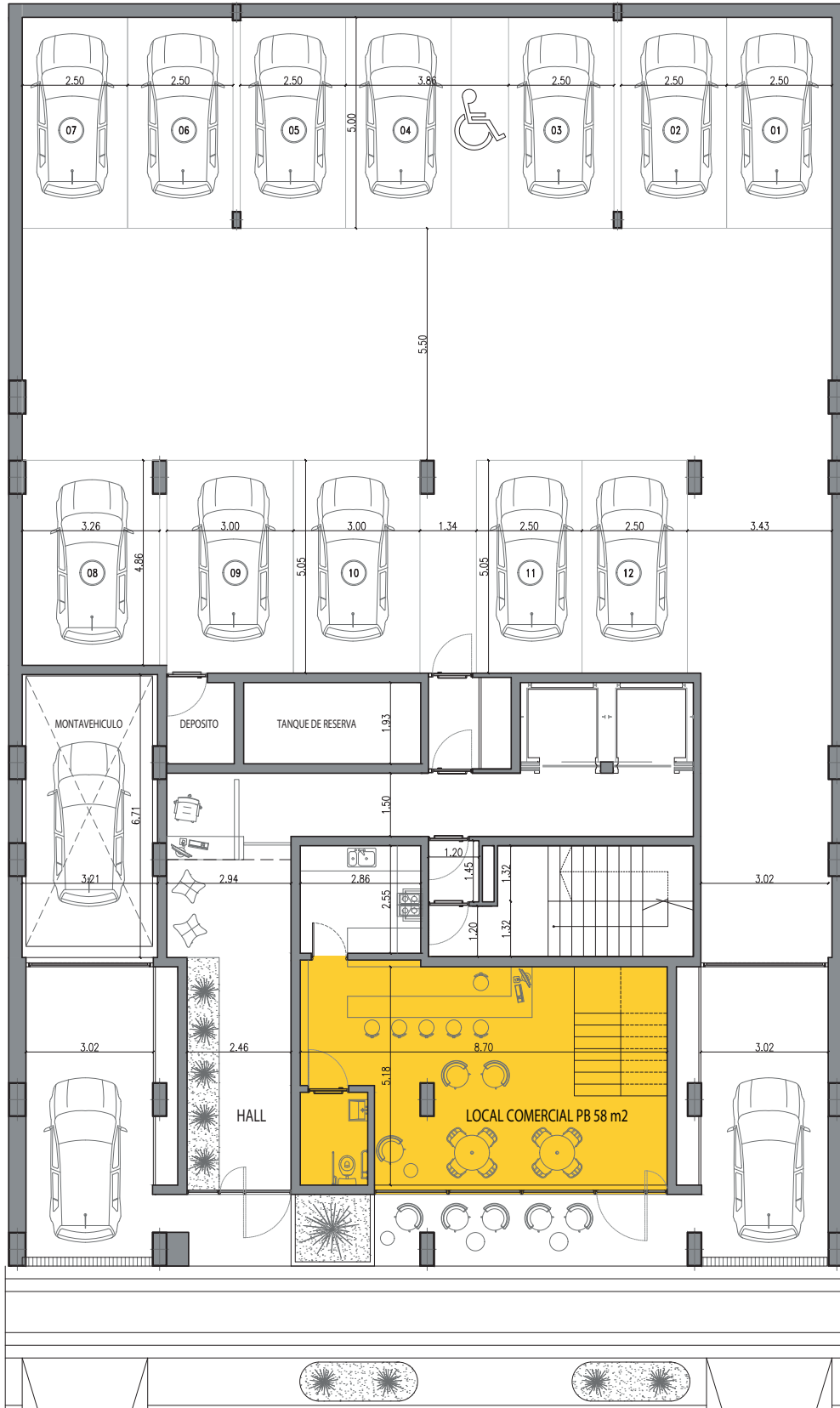



LOCAL COMERCIAL

Nivel 1

Superficie: 58 m²

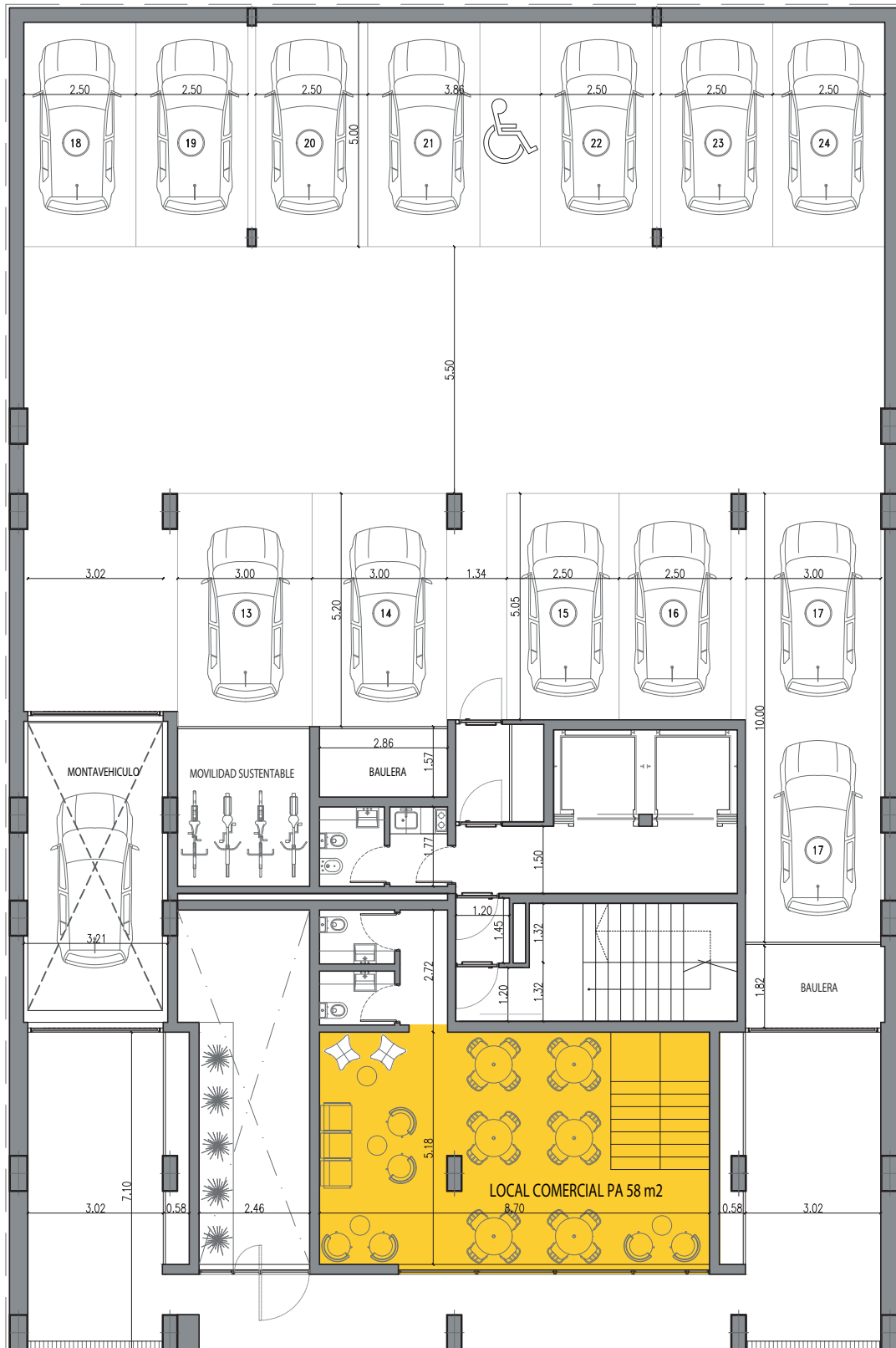

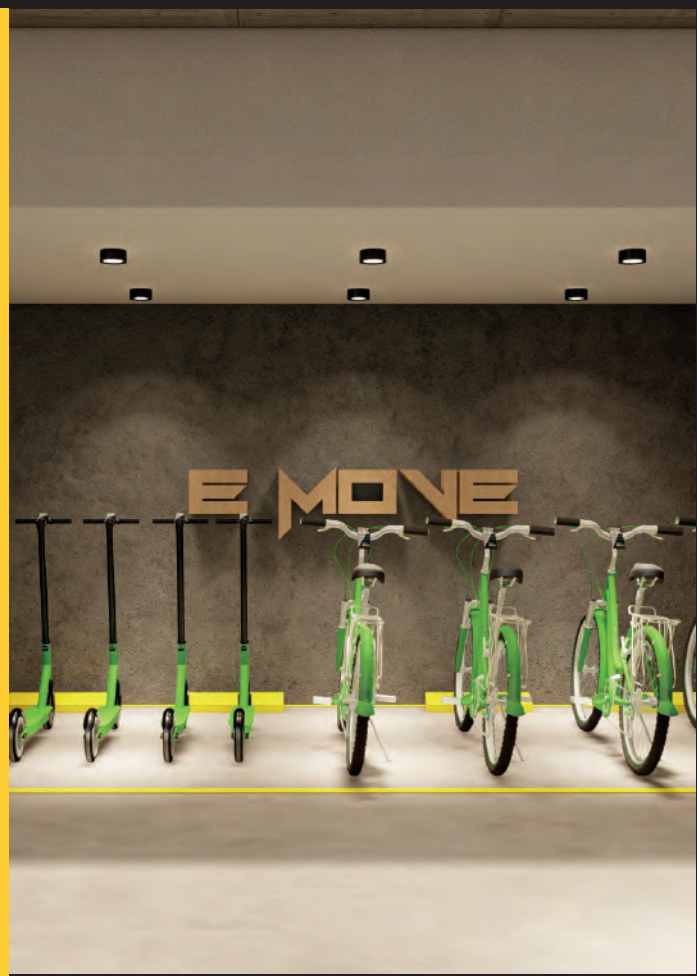

COCHERA SUSTENTABLE

Nivel 1

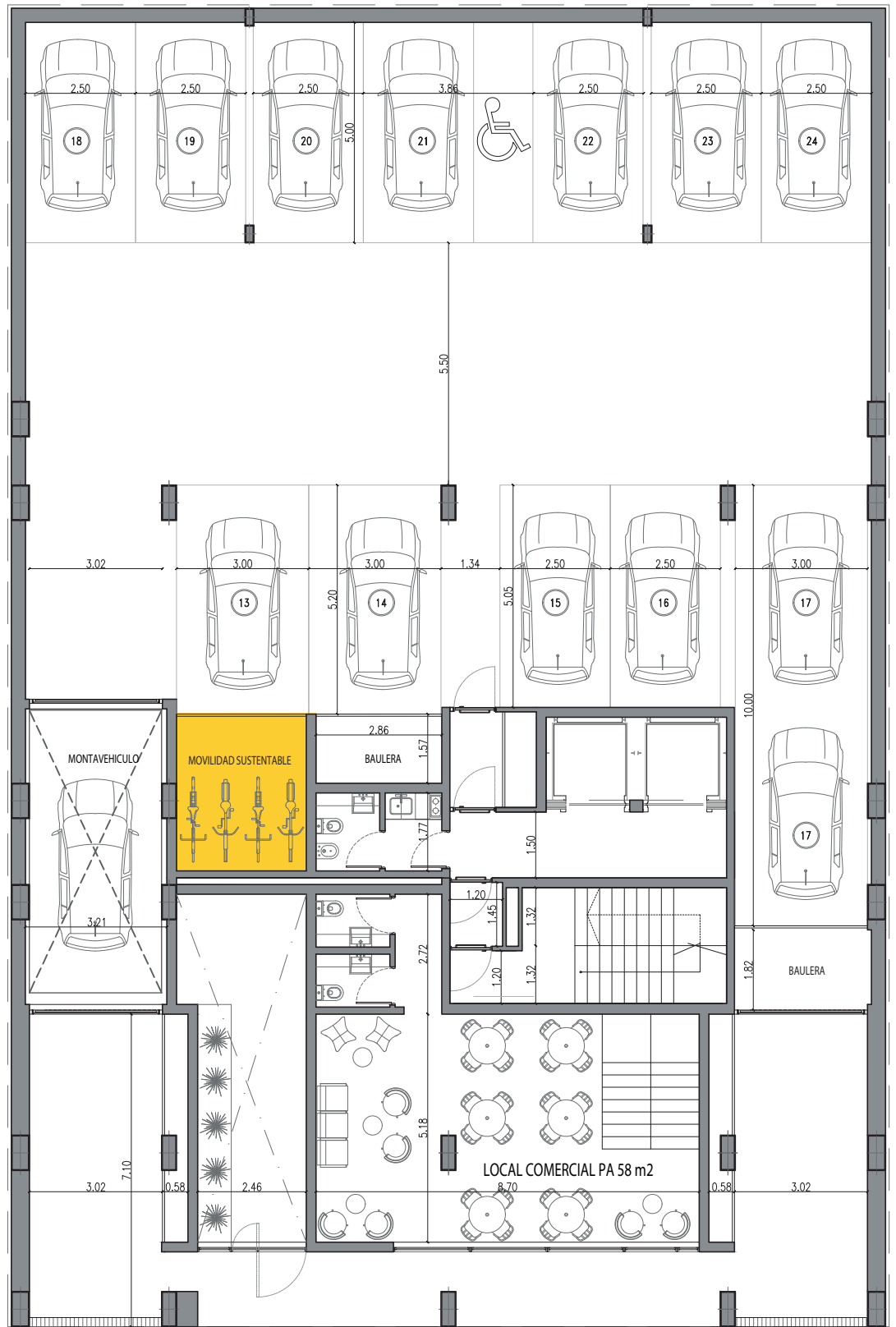

COCHERA SUSTENTABLE



OFICINAS

Nivel 2 al 4
6 | 13 al 15





OFICINAS

Superficie: 52 m2

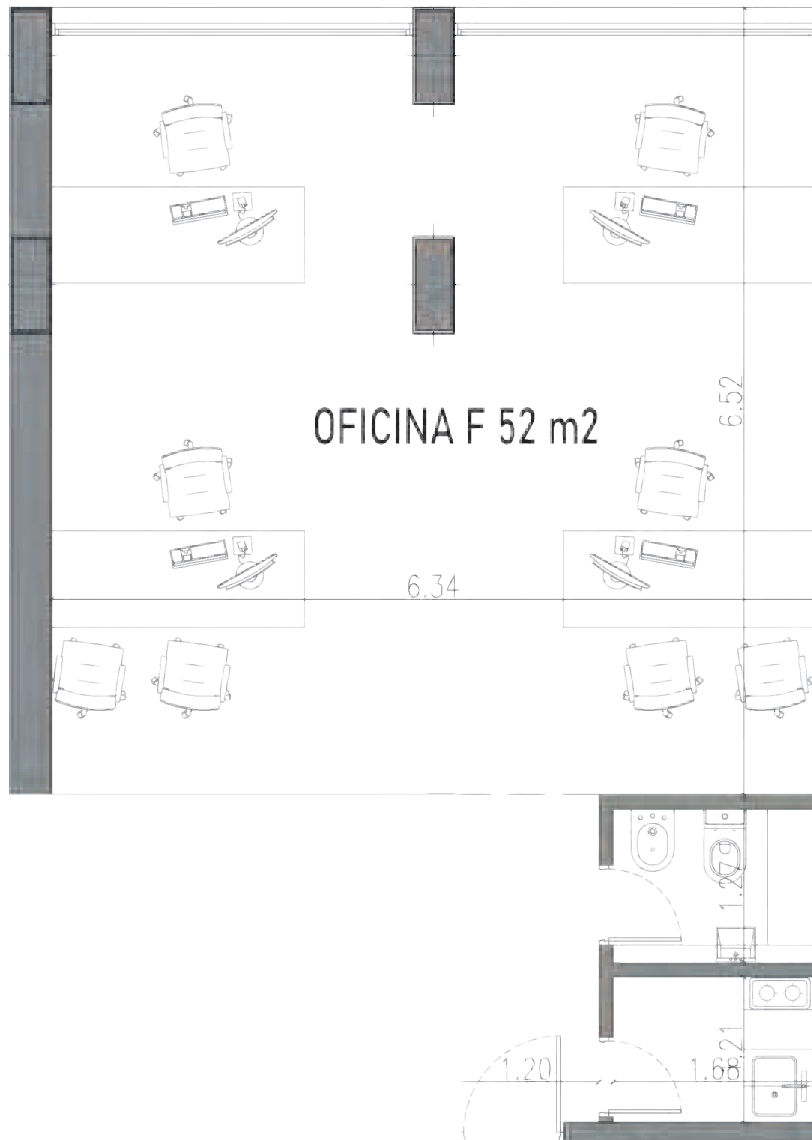



OFICINAS

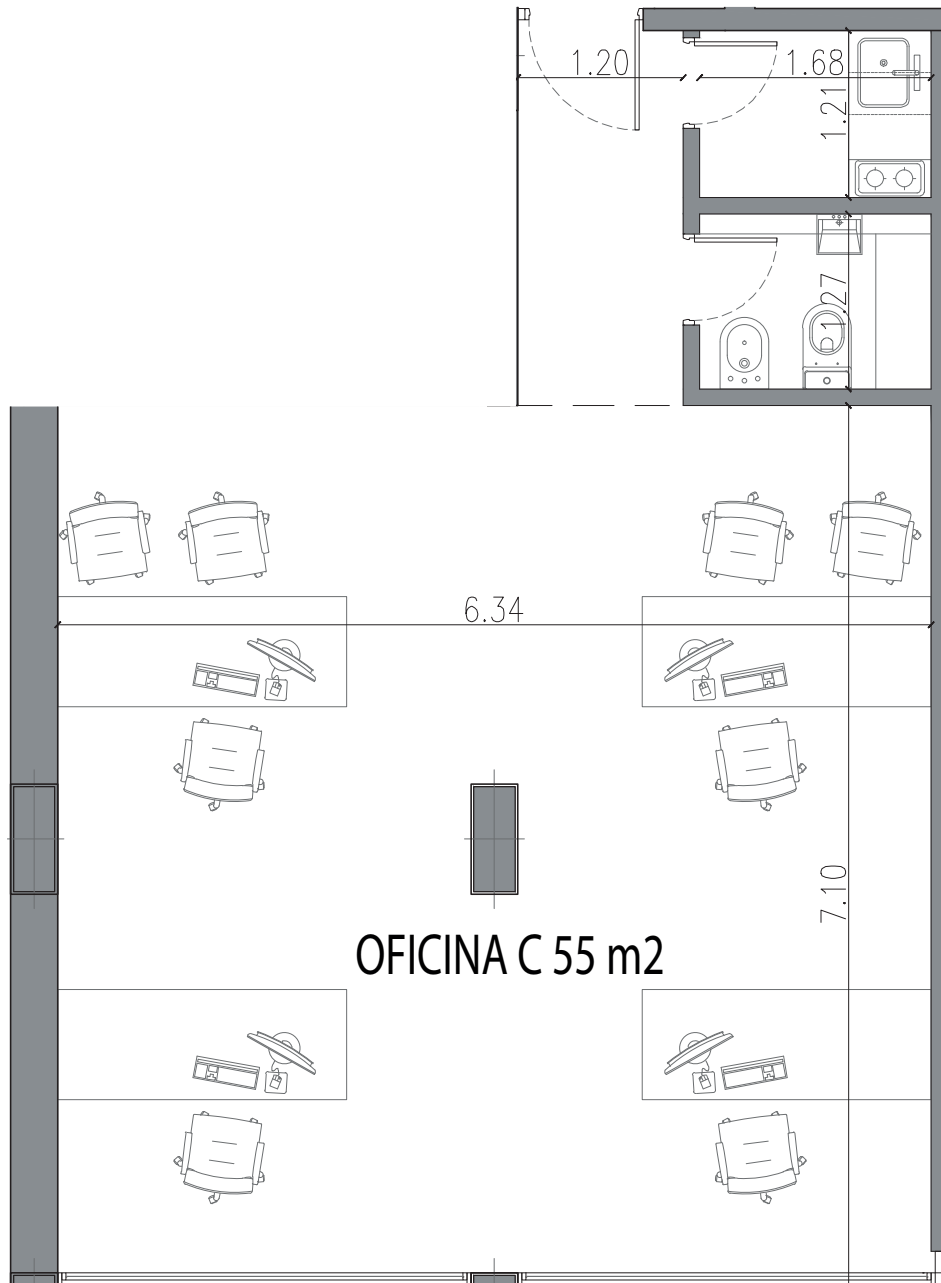

Superficie: 55 m²



OFICINAS

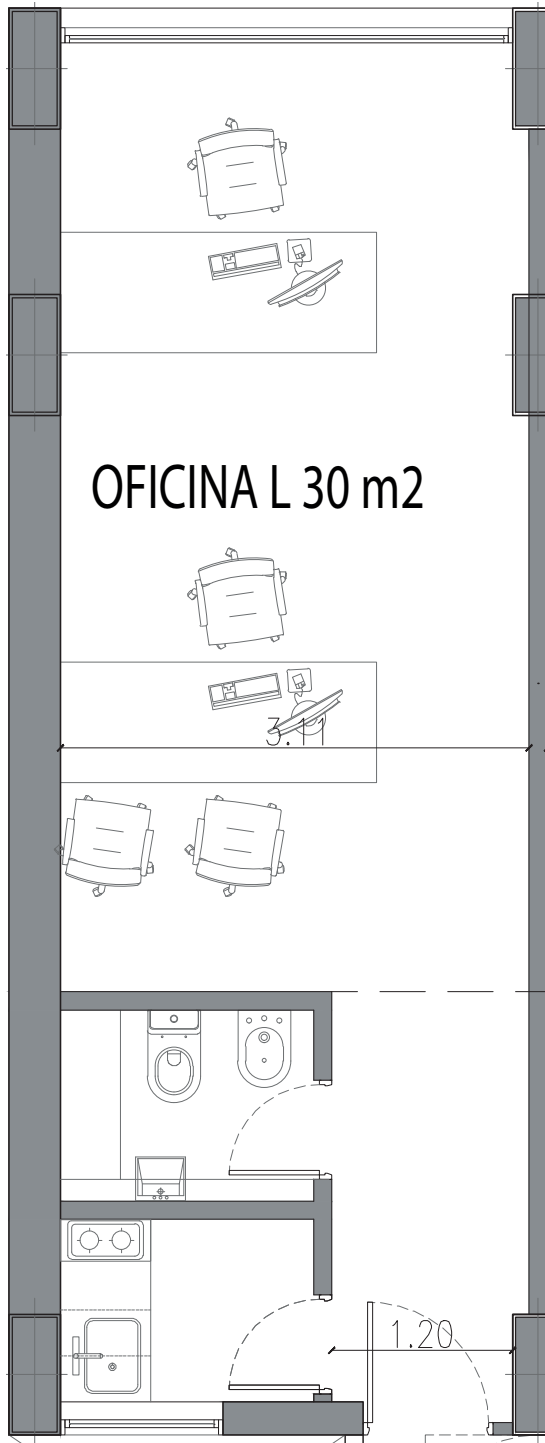

Superficie: 30 m²

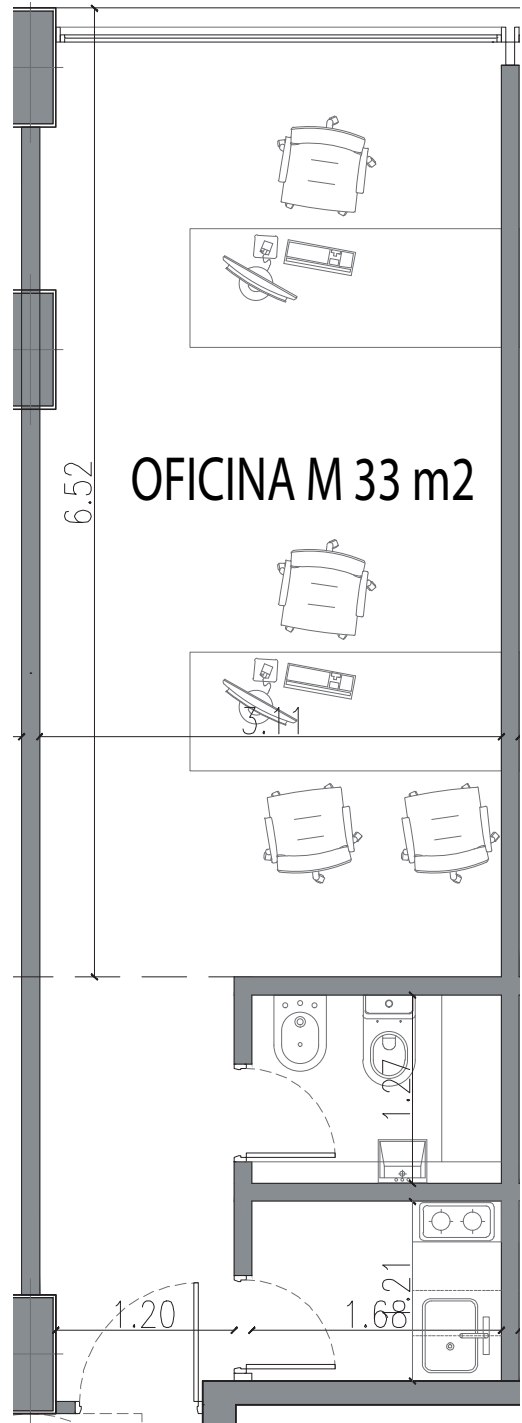

Superficie: 33 m²



OFICINAS

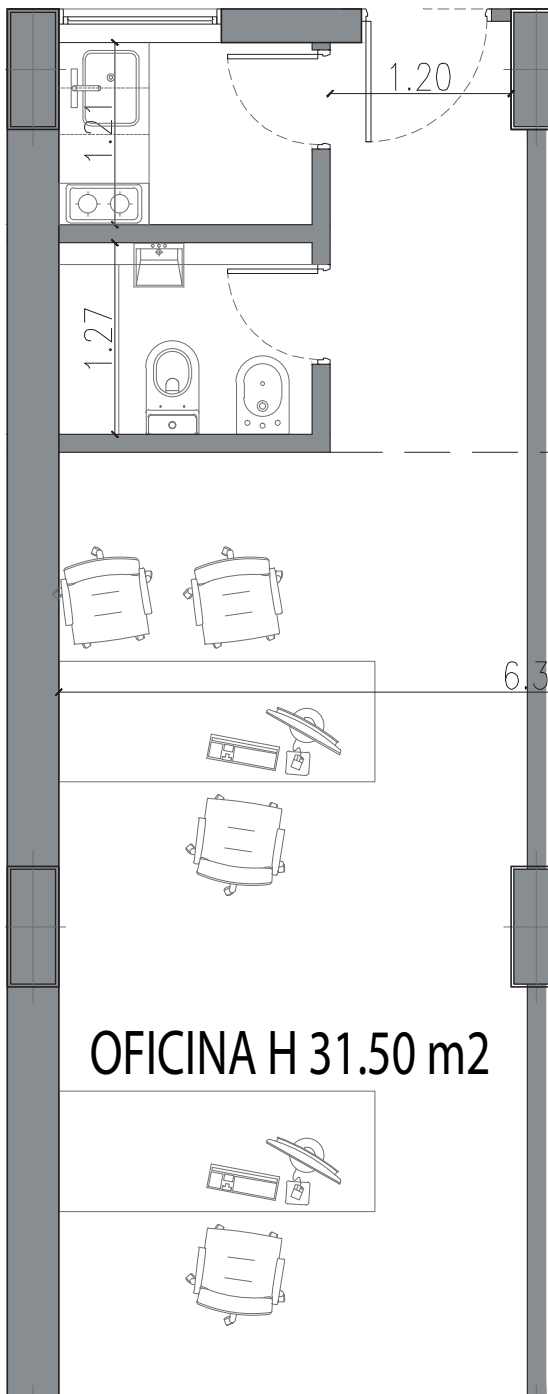

Superficie: 31 m2



DEPARTAMENTOS PARA ALQUILER TEMPORÁRIO

Nivel 5 | 7 al 12





SALA DE REUNIONES

Nivel 4



SALA DE REUNIONES

Superficie: 52 m²

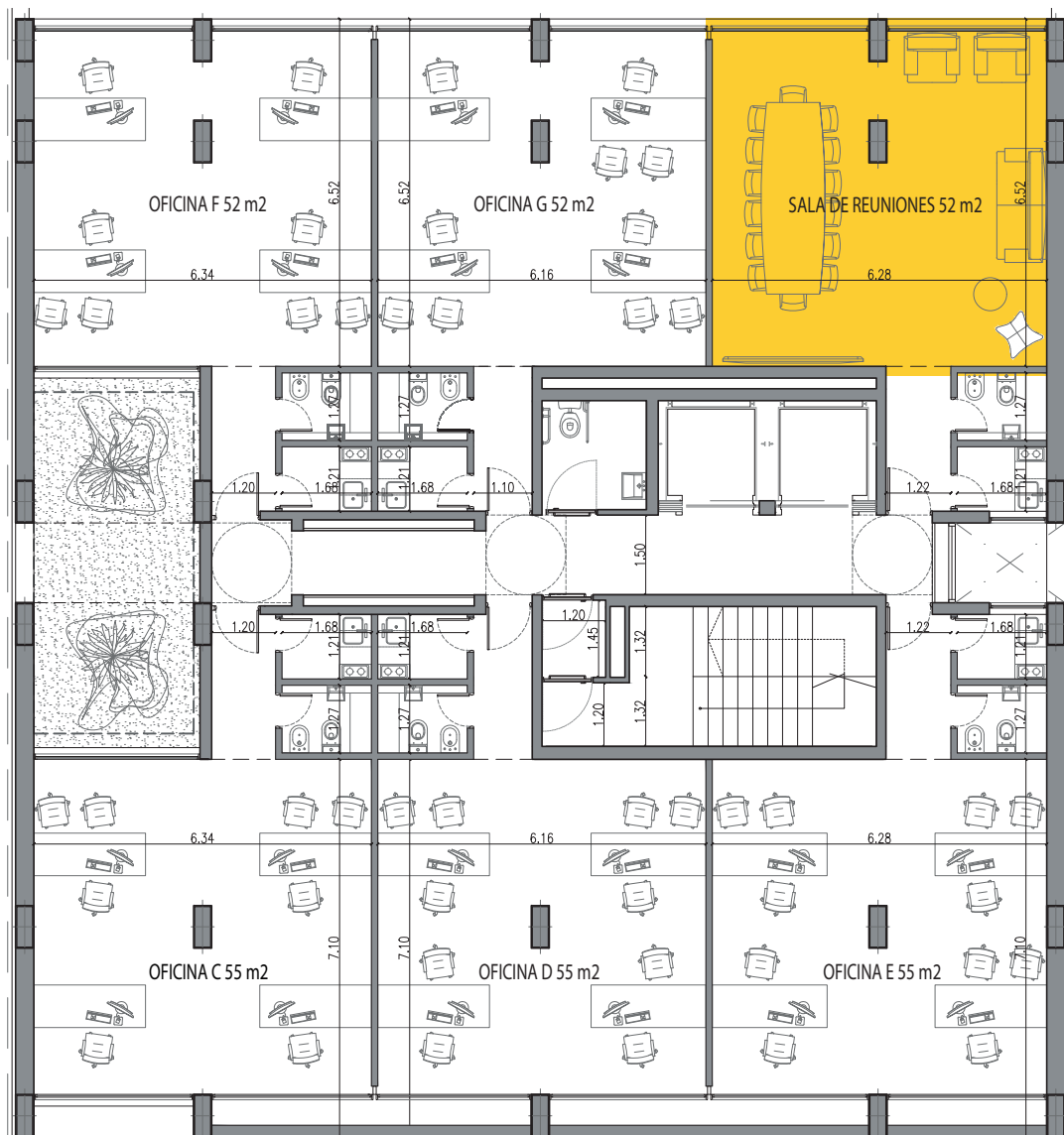



SUM

Nivel 16



GIMNASIO

Nivel 16





LAUNDRY

Nivel 16

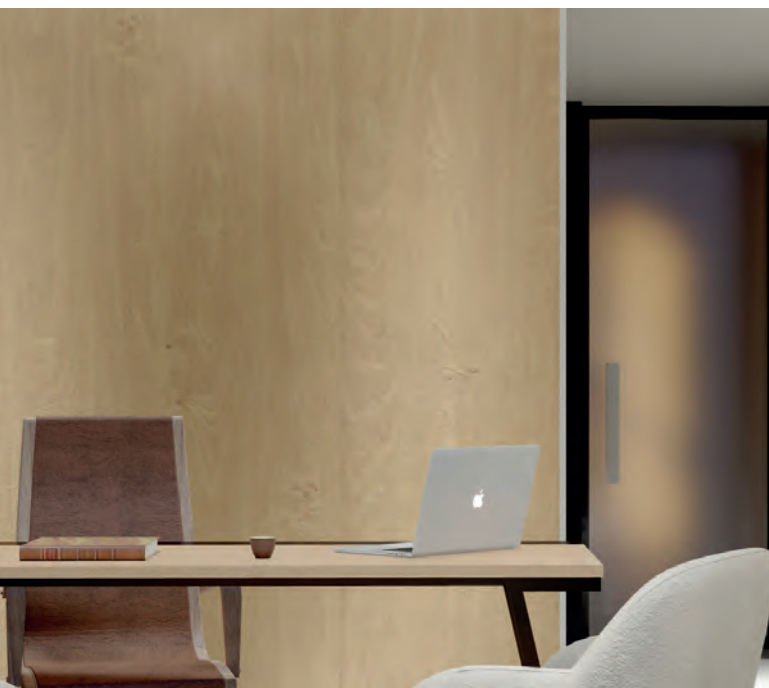
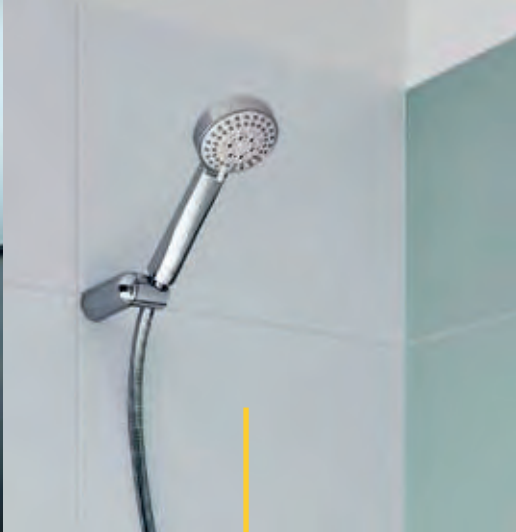

TERMINACIONES

GRIFERÍA

Cierre cerámico marca FV, Roca Argentina, Peirano o similar.

ARTEFACTOS DE BAÑO

Marca Roca Argentina, Ferrum o similar.

CLIMATIZACIÓN

Sistema de climatización variable VRV central (frío/calor)

ABERTURAS DE ALUMINIO O PVC

Con doble vidrio hermético. Sustentables. Eficientes energéticamente.

PISOS

Porcelanato primeras marcas.

REVOQUES

En yeso.

CIELO RASO

En hormigón visto.

Juan B. Justo

Juan B. Justo

Salta

Santiago del Estero 45



Santiago del Estero

San Martín

San Martín



El lugar donde
inician **tus sueños**



NEW HORIZONS



DOMMO PARK

BUSINESS CENTER